

ALWAYS INCLUDE SERIAL NO. OF
PLOW WHEN ORDERING PARTS

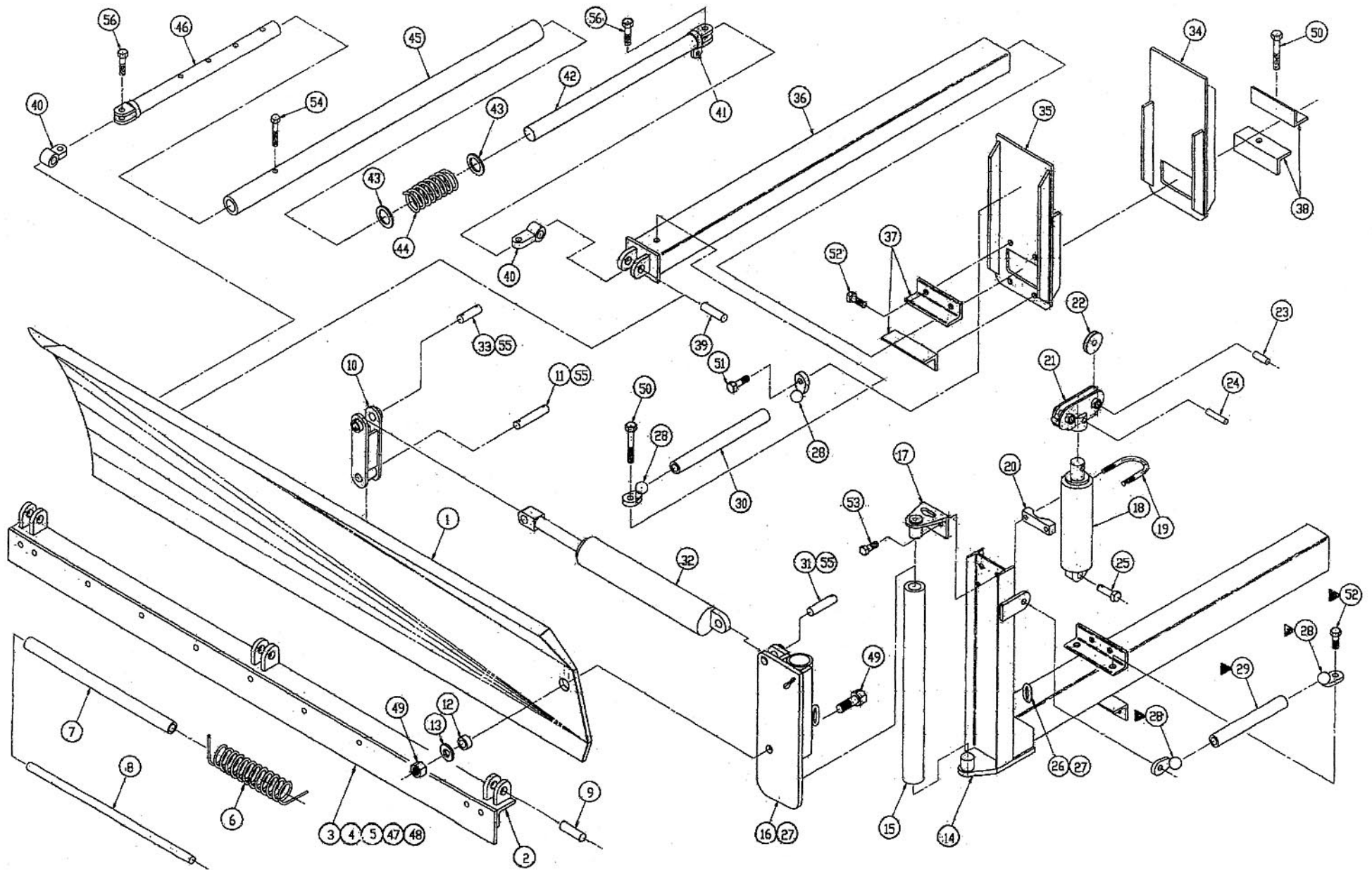

The Gledhill Road Machinery Co.

PARTS DRAWING FOR
STD. PATROL ING MODELS
9FRPWTE; 10FRPWTE; & 11FRPWTE PD-1198

ITEM	PART #	REQ.	NAME/DESCRIPTION
	PD-1061-A	A	9FRPW-TE PATROL WING
	PD-1061-B	B	10FRPW-TE PATROL WING
	PD-1061-C	C	11FRPW-TE PATROL WING
1	12647-C	1	9FRPW-TE WING MOLDBD. ASSY. COMPLETE
1	12239-C	1	10FRPW-TE WING MLBD. ASSY. COMPLETE
1	12701-C	1	11FRPW-TE WING MLBD. ASSY. COMPLETE
2	12648-DB	1	CUTTING EDGE BACKER ANGLE ASSY.
2	12240-DB	1	CUTTING EDGE BACKER ANGLE ASSY.
2	12436-DA	1	CUTTING EDGE BACKER ANGLE ASSY.
3	A-53793-1	1	CUTTING EDGE
3	A-53793-2	1	CUTTING EDGE
3	A-53793-3	1	CUTTING EDGE
4	6511-A1	1-1-1	RIGHT HAND CURB SHOE
5	6511-A2	1-1-1	LEFT HAND CURB SHOE
6	14789-A	4-4-4	TORSION SPRING
7	12647-C22	2	SPRING SUPPORT PIPE
8	5175-A152	1	PIN 1-1/4 X 96 WITH COTTERS
8	5175-A145	2-2	PIN 1-1/4 X 41-1/2 WITH COTTERS
9	5175-A126	3-3	PIN 1-1/4 X 4-1/2 WOTH COTTERS
10	12398-A	1-1-1	FLOATING LINK WELDMENT
11	5176-A180	1-1-1	PIN 1-1/4 X 6-1/4
12	7445-A40	1-1-1	BUSHING
13	7445-A43	1-1-1	WASHER
14	12641-D	1-1-1	FRONT POST & CROSS TUBE WELDMENT -STD.
15	F-222-3	1-1-1	HINGE SLIDE TUBE
16	12574-C	1-1-1	HINGE SLIDE BRACKET
17	12237-B	1-1-1	TOP MOUNTING ANGLE WELDMENT
18	P-114-71	1-1-1	FRONT LIFT CYLINDER -SEE PD- 1084
19	11996-A	1-1-1	U-BOLT
20	11997-A	1-1-1	CRADLE BLOCK
21	12619-B	1-1-1	SHEAVE BLOCK
22	12623-A	2-2-2	SHEAVE ASSY. -COMPLETE
23	12622-A	2-2-2	SHEAVE- 3-1/2"
24	5175-A150	1-1-1	SHAFT WITH COTTER
25	11685-A2	1-1-1	PIN WITH COTTERS
26	12626-D11	1-1-1	PIN 1 X 4 WITH COTTERS
27	12626-D12	4-4-4	CABLE CABLE CLAMP
28	10090-B	6-6-6	CAST END FITTING
29	12626-D7	2-2-2	SUPPORT PIPE
30	INS-307-10	1-1-1	BRACE PIPE

ITEM	PART #	REQ.	NAME/DESCRIPTION
31	5176-A38	1-1-1	PIN 1-1/4" X 4-1/4
32	P-114-72	1-1-1	HEEL LIFT CYLINDER - SEE PD- 1092
33	5175-A179	1-1-1	PIN 1-1/4" X 5-1/4
34	11870-BLH	1-1-1	LEFT HAND SIDEPLATE WITHOUT HOLES
35	11870-BRH	1-1-1	RIGHT HAND SIDEPLATE WITH HOLES
36	11869-B	1-1-1	REAR CROSS TUBE WELDMENT
37	11871-A	2-2-2	MOUNTING ANGLE
38	11872-A	2-2-2	(1) TOP & (1) BOTTOM MOUNTING ANGLE
39	5185-A185	2-2-2	PIN WITH COTTERS
40	C-31153-3F	2-2-2	MALE UNIVERSE SHACKLE 1/2" WITH 11/16" HOLE
41	5322-A3	1-1-1	SHACKLE 1/2" WITH 11/16" HOLE
42	11882-B	1-1-1	ROD ASS'Y
43	A-45146	4-4-4	WASHER
44	A-45145	1-1-1	SPRING
45	11880-B	1-1-1	PIPE 2-1/2" X 55-1/2
46	11881-B	1-1-1	ROD ASS'Y
47	5308-A3	4-4-4	CARRIAGE BOLT 5/8- 11U UNC X 3 LG. W/N & LW
48	5308-A2	8-7-6	CARRIAGE BOLT 5/8-11 UNC X 2 LG. W/N & LW
49	12003-A2	1-1-1	CAPSCREW GR.5 1-1/4 - 7 UNC X 6 LG. W/N & LW
50	5308-A148	2-2-2	CAPSCREW GR.5 3/4 -10 UNC X 6LG. W/N & LW
51	5308-A66	1-1-1	CAPSCREW GR.5 3/4- 10 UNC X 3LG. W/N & LW
52	5308-A75	8-8-8	CAPSCREW GR.5 3/4- 10 UNC X 2-1/2 LG. W/N & LW
53	5308-A4	2-2-2	CAPSCREW GR.5 3/4- 10 UNC X 2 LG. W/N& LW.
54	5308-A24	1-1-1	CAPSCREW GR.5 5/8- 11 UNC X 4-1/2 LG. W/N & LW.
55	5308-A60	5-5-5	CAPSCREW GR.5 3/8- 16 UNC X 2-1/2 LG/ W/N & LW.
56	5308-A17	2-2-2	CAPSCREW GR.5 3/4- 10 UNC X 3-1/2 LG. W/N & LW.

The Gledhill Road Machinery Co.

PARTS DRAWING FOR
 STD. PATROL ING MODELS
 9FRPWTE; 10FRPWTE; & 11FRPWTE PD-1198

INSTALLATION INSTRUCTIONS

ITEM	PART #	REQ.	NAME/DESCRIPTION
1		1	FF HITCH ASS'Y
2	12626-D	1	FRONT POST SS'Y
3	16286-C	1	9' WING MLBD. ASS'Y (SHOWN)
4	11870-BA	1	LH. REAR SIDE PLATE
5	11870-B	1	RH. REAR SIDE PLATE
6	16287-B	1	REAR CROSS TUBE
7	14658-A7	4	REINF. BAR
8	11872-A	1-1-3	MTG. ANGLE
9	11871-A	2	MTG. ANGLE
10	10090-B	6	END FITTING
11	F-245-25	3	BRACE PIPE
12	P-114-72	1	HEEL LIFT CYCLE
13	11879-D	1	PUSH BRACE ASS'Y
14	P-132-40	1	CHAIN LINK
15	P-132-40	1	CHAIN LINK
16	P-132-45	1	CHAIN
17	P-116-199	1	DOUBLE CLEVIS
18	12003-A2	1	CAPSCREW GR. 5
19	7445-A43	1	WASHER
20	5175-A64	2	PIN
21	P-111-158	1	CHECK VALVE (REQ'D ON ALL WINGS)
22	P-111-66	1	FLOW CONTROL VALVE
23	F-212-1	1	OUTSIDE TUBE
24	F-203-1	1	INSIDE TUBE
25	14530-B4	1	STOP BAR
26	14530-B3	1	MTG. PLATE (TUBE STOP)
27	5175-A141	1	PIN
28	5176-A38	1	PIN
29	14530-B5	1	BRACE (TUBE STOP)
30	15979-B	2	TIMBREN SPRING
31	5308-A75	16	CAPSCREW GR. 5
32	5308-A66	1	CAPSCREW GR. 5
33	5308-A62	2	CAPSCREW GR. 5
34	5308-A207	3	CAPSCREW GR. 5
35	5308-A25	2	CAPSCREW GR. 5

1. Install front frame hitch, item #1, & front post ass'y. #2, according to drwg. for hitch that is supplied.
2. Install rear side plates, items #4 & 5, as shown. Use bolt holes already in truck frame wherever possible.
3. Locate reinforcing bars, item #7, against inside of rear side plates & against bottom flange of truck frame. Weld reinforcing bars to rear side plates only. DO NOT weld to truck frame.
4. Install rear cross tube, item #6, as shown.
5. Bolt mtg. angles, item #9, to r.h. rear side plate, item #5. Tack weld mtg. angles to rear cross tube.
6. Tack weld top mtg. angle, item #8, to L.H. rear side plate, item #4. Use mtg. angle as a template & mark hole location on cross tube.
7. Remove cross tube. Finish weld mtg. angles to cross tube, drill 13/16 dia. hole thru cross tube per location described in step #6.
8. Locate bottom mtg. angle, item #8. by lining up bolt hole for bolt, item #33, & allowing clearance for cross tube. Finish weld top & bottom mtg. angles to side plate.
9. Reinstall finished cross tube & bolt in place.
10. Install end fittings, item #10, as shown. Measure distance between end fittings. Add 7/8" to this measured length & cut pipe, item #11, to this length. Install pipe to end fittings as shown & weld all around.

ALWAYS INCLUDE SERIAL NO. OF
PLOW WHEN ORDERING PARTS

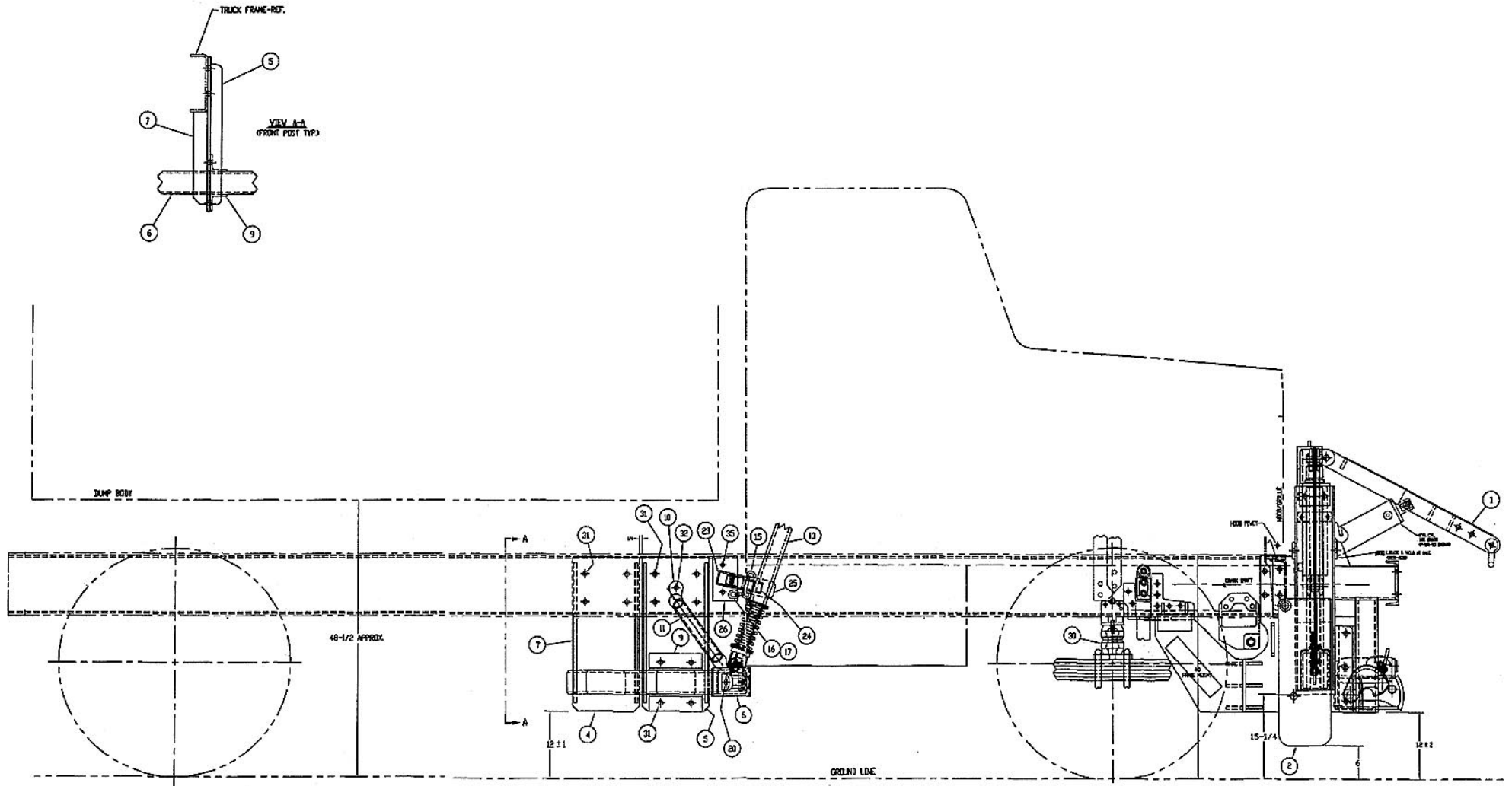

The Gledhill Road Machinery Co.

FRONT PATROL WING (O.D.O.T. & STD)
(9FRPW-TE WING SHOWN) 16874-D